

# GREX<sup>®</sup>

## AF64

15 Gauge Angle Finish Nailer

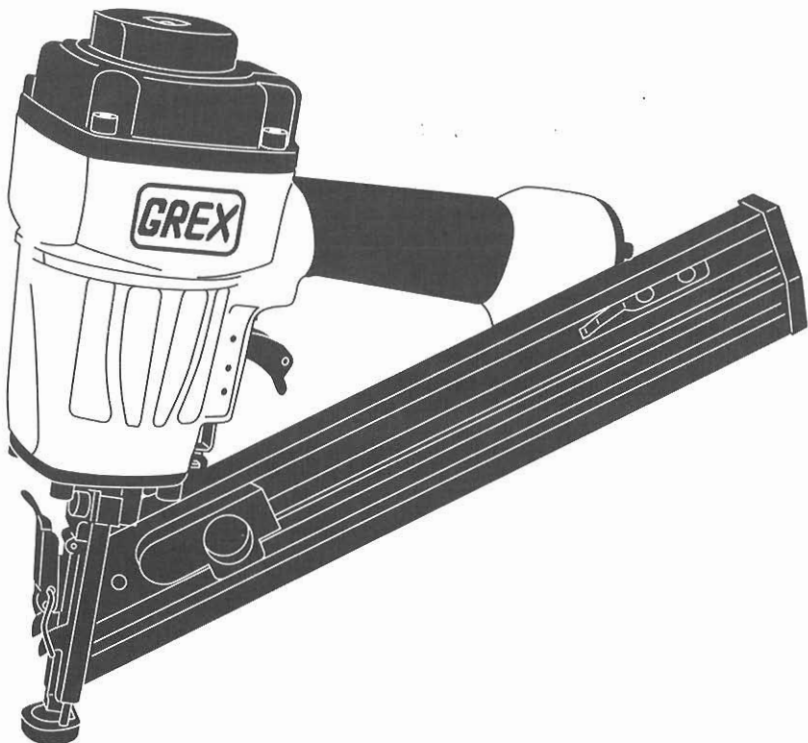

**CAUTION:** Before attempting to use or service this tool, carefully read and understand all rules and instructions for safe operation.



**NOTE:** This manual includes safety warnings, operation instructions, and tips on the maintenance and inspection of this tool.



**WARNING:** Do not attempt to operate this tool unless you have read and fully understood all instructions and safety precautions contained in this manual. Failure to comply can result in serious injury to yourself and bystanders.

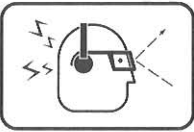

**1. Always wear protective equipment.**

To prevent eye injuries, safety glasses should be worn by the operator and others in the work area that conforms to requirements of the American National Standards Institute, ANSI Z87.1 & provides both frontal & side protection. Always wear other personal protective equipment such as hearing protection & hard hats.



**2. Use only clean, dry, regulated compressed air.**

Do not operate the tool on oxygen, carbon dioxide, combustible gases or any other bottled gases; the tool will explode and cause serious injury.



**3. Operate within the proper air pressure range.**

Do not exceed the maximum recommended air pressure of 120 psi (8.3 bar) and never connect the tool to air pressure which potentially exceeds 200 psi (13.7 bar) as the tool can burst.

**4. Use the correct type of air hose.**

Air hose must have a minimum working pressure rating of 150 psi (10.4 bar) or 150% of the maximum pressure produced in the system, whichever is higher.

**5. Do not operate tool near flammable substances.**

Volatile fumes from these substances can be drawn into the compressor and compressed together with the air, causing risk of explosion.

**6. Never point tool toward yourself or anyone else.**

Always assume tool contains fasteners. Keep tool pointed away from yourself and others at all times. Never engage in horseplay with tool. Respect tool as a working implement.

**7. Keep visitors away.**

Do not let visitors handle the tool. All visitors should be kept safely away from the work area.

**8. Inspect tool condition and maintain with care.**

Make sure all screws and caps are securely tightened at all times. Never use tool if parts are missing or damaged, leaks air, or needs repair. Keep the tool clean and lubricated for better and safer performance.

**9. Drive fasteners carefully.**

Never drive fasteners into materials too hard to penetrate. Do not drive fasteners into thin boards or near corners and edges of work piece; they may be driven through or away from work piece. Do not drive fasteners on top of other fasteners or with tool at too steep an angle; the fastener can ricochet and cause personal injury or injury to bystanders.

**10. Load fasteners carefully.**

Always disconnect air supply from tool before loading fasteners. Have tool pointed downwards and away from yourself or any bystanders at all times.

**11. Use only relieving couplers on tool and air supply hose.**

The tool and air supply hose must have a hose coupling such that all pressure is removed from the tool when the coupling is disconnected. If not, the tool can remain charged with air after disconnecting and be able to drive a fastener even after being disconnected.

**12. Disconnect air hose from tool when:**

Disconnect tool from air before performing any tool maintenance, clearing jammed fasteners, leaving work area, moving tool to another location, or handing the tool to another person.

**13. Empty fasteners from magazine when:**

Remove all fasteners from tool before connecting air hose, doing tool maintenance, or when operation has been completed or suspended.

**14. Dress properly.**

Be sure not to wear clothing or jewelry that may be caught in moving parts. Rubber gloves and non-slip footwear are recommended when working outdoors. Wear protective hair covering to contain long hair.

**15. Handle tool carefully and correctly.**

Operate tool according to this manual. Never allow the tool to be operated by children, individuals unfamiliar with its operation or unauthorized personnel. Because of high pressure in the tool, cracks in the surfaces are dangerous. To avoid this, do not drop the tool or strike the tool against hard surfaces; and do not scratch or engrave signs on the nailer. Handle the tool carefully.

**16. Keep work area clean.**

Cluttered areas invite injuries. Clear work areas free of unnecessary tools, debris, furniture, etc.

**17. Stay alert.**

Watch what you are doing. Use common sense. Do not operate tool when tired, or under the influence of alcohol, drugs, or medication that causes drowsiness.

**18. Do not overreach.**

Keep proper footing and balance at all times.

**19. Store idle tool.**

When not in use, tool should be kept in dry, and high or locked-up places - out of reach of children.

**20. Never use tool for application other than those specified in this manual.**

Using tool for applications other than those intended for may harm the tool, cause personal injury to operator and injury to bystanders.

**21. Use only parts, accessories or fasteners supplied or recommended by GREX.**

Unauthorized parts, accessories, or fasteners may void your warranty and can lead to malfunction and resulting injuries. Do not modify the tool without written approval from GREX.

**EMPLOYER'S RESPONSIBILITIES**

1. Keep this manual available for use by all people assigned to use this tool.
2. Employer must enforce compliance with safety warnings & all instructions contained in this manual.
3. For personal safety & proper operation of this tool, read and follow all of these instructions carefully.
4. Ensure that tools are used only when operators & others in work area are wearing safety protection.
5. Enforce the use of safety protection, especially safety eyewear, by operators and others in work area.
6. Keep tools in safe working order and maintain them properly.
7. Ensure that tools that require repair are not further used before repair.



**IMPORTANT:** Save this manual and review it frequently for continuing safe operation.



**NOTE:** The following illustration shows the correct mode of connection to the compressed air system which will increase the efficiency and useful life of the tool.

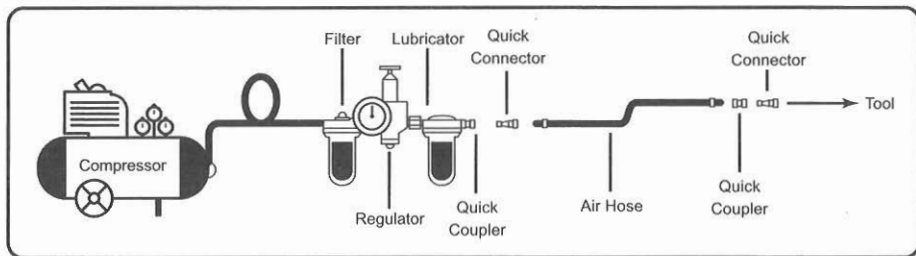

### 1. Power Source

- Use clean, dry, regulated compressed air as a power source for the tool.
- Air compressors used to supply compressed air to this tool must comply with the requirements of the latest version of ANSI Standard B 19.3 "Safety Standard For Compressors For Process Industries".
- Moisture or oil in the air compressor may accelerate wear and corrosion in the tool.
- Never use oxygen, combustible gases or any other bottled gases.

### 2. Filter-Regulator-Lubricator

- Use a regulator with a pressure range of 0-120 psi (0-8.3 bar).
- Filter-regulator-lubricator units supply an optimum condition for the tool and extend tool life.
- These units should always be used:

Filter	The filter removes moisture and dirt mixed in the compressed air. Drain daily unless fitted with an automatic drain. Keep the filter clean by regular maintenance.
Regulator	The regulator controls the operating pressure for safe operation of the tool. Inspect the regulator before operation to be sure it operates properly.
Lubricator	The lubricator supplies an oil mist to the tool. Inspect the lubricator before operation to be sure the supply of lubricant is adequate.

### 3. Air Hose

Air hose must have a minimum working pressure rating of 150 psi (10.4 bar, 10.6 kgf/cm<sup>2</sup>) or 150% of the maximum pressure produced in the system, whichever is higher.

### 4. Hose Coupling

Install a 1/4" NPT male plug at the air inlet of the tool. A female coupler must be installed on the air hose. The hose coupling (male-female coupler) must remove all pressure from the tool when disconnected. Never use a non-relieving coupler on the tool. Doing so will leave the tool charged with air after disconnecting and be able to drive a fastener even after being disconnected.

### 5. Air Consumption

Using the air consumption table and the air compressor size formula, find the correct compressor size.

Air Consumption Table

Operating pressure	psi (bar) (kgf/cm <sup>2</sup> )	80 (5.5) (5.6)	90 (6.2) (6.3)	100 (6.9) (7)
Air consumption	ft <sup>3</sup> /cycle (ltr/cycle)	0.078 (2.2)	0.088 (2.5)	0.095 (2.7)

Air Compressor Size Formula

Amount of air required (CFM)  
= number of nailers  
x average nails driven each minute per nailer  
x air consumption at given air pressure  
x safety factor (always 1.2)

NAME OF PARTS

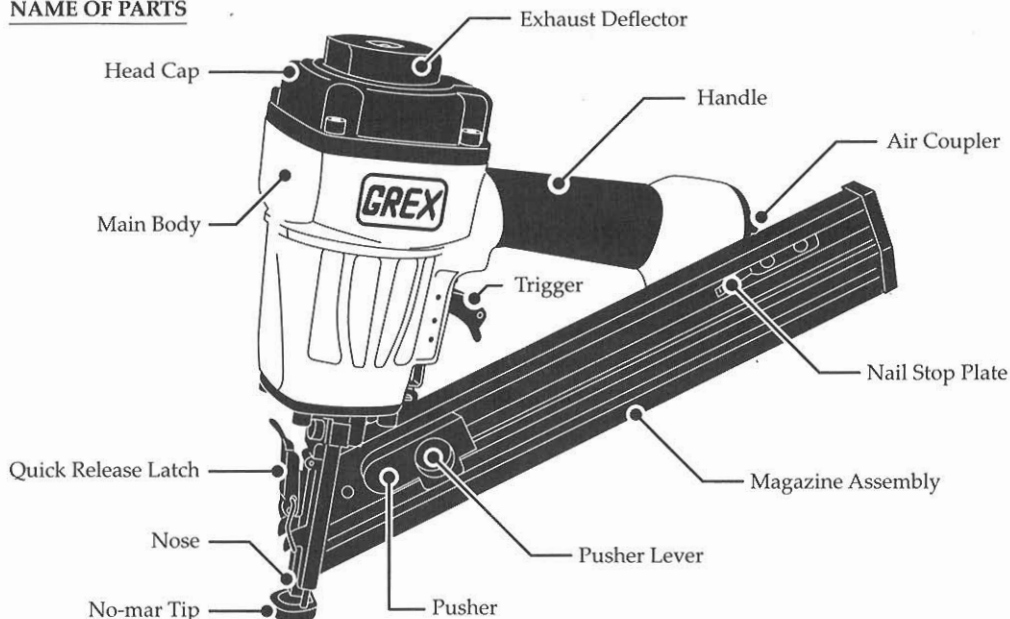

TECHNICAL SPECIFICATIONS

Dimensions	13" (330mm) L x 12" (305mm) H x 3.5" (89mm) W
Weight	5.3 lbs (2.4 kgs)
Operating Pressure	70 ~ 100 psi (4.8 ~ 6.9 bar)
Air Inlet	1/4" NPT
Fastener Type	15 Gauge Angle Finish Nails
Fastener Range	1" ~ 2-1/2" (25 ~ 64mm) Lengths

GREX FASTENERS ITEM NO.

Item No.	Length	Quantity
GAN15-25	1" 25mm	4,000 / Box
GAN15-32	1-1/4" 32mm	4,000 / Box
GAN15-38	1-1/2" 38mm	4,000 / Box
GAN15-45	1-3/4" 45mm	4,000 / Box
GAN15-50	2" 50mm	4,000 / Box
GAN15-57	2-1/4" 57mm	4,000 / Box
GAN50-64	2-1/2" 64mm	4,000 / Box

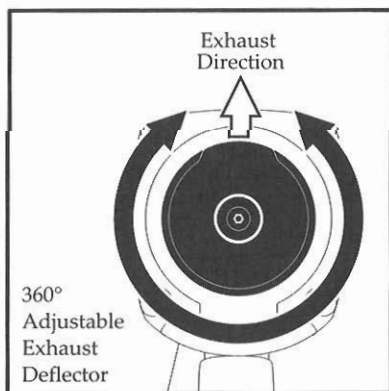

SUGGESTED APPLICATIONS

Cabinet assembly, trim and molding, furniture finish work, light wood assembly, planar boxes, paneling, external softwood trim, window beading, scribe molding, door and window casings ...



**CAUTION:** Read section titled "Safety Instructions" on pages 1 and 2 before operating tool.

### PRE-OPERATION CHECKLIST

1. Wear safety glasses or goggles.
2. Do not connect the air supply.
3. Remove all fasteners from tool.
4. Inspect all screw tightness.
5. Check for any visual damages to the exterior of the tool.
6. Check that all moving parts operate smoothly (trigger, magazine pusher).
7. Adjust air supply to 70 psi. Connect air supply.
8. Check for any air leakage. The tool must not leak air to operate properly.
9. Adjust for proper air supply pressure by following steps in section "Adjusting Air Pressure" below.

### ADJUSTING AIR PRESSURE

- Adjust the air pressure within the recommended operating pressure of 70 ~ 100 psi (4.8 ~ 6.9 bar).
- The correct air pressure is the lowest pressure which will complete the job. Using the tool at excessively high pressures than required will unnecessarily over stress the tool and may damage the work piece and decrease the life of the driver.
- Before driving fasteners into the work piece, test drive fasteners on material of similar type to be used in the actual application to determine the proper air pressure.

### LOADING FASTENERS

1. Disconnect tool from air supply.
2. Slide a strip of fasteners through the slot at the end of the magazine. Make sure the fasteners are oriented in the correct direction. Figure 1.
3. Slide the strip of fasteners all the way to the front of the nose. Figure 2.
4. While pressing down on the Pusher Lever, pull the Pusher to the rear of the magazine until the Pusher is behind the strip of fasteners. Figure 3.
5. Release the Pusher Lever and make sure the Pusher is securely pushing the strip of fasteners forward toward the nose. Figure 4.



**CAUTION:** When loading fasteners, ALWAYS remove all existing fasteners of different lengths. Loading fasteners of different lengths may cause jamming and/or damage to driver.



**WARNING:** Keep yourself and other persons away from the nose to avoid possible injury.



**WARNING:** DO NOT insert different lengths and/or type of fasteners at the same time. Doing so can result in jamming and/or damage to driver.

**!** CAUTION: Read section titled "Safety Instructions" on pages 1 and 2 before operating tool.

## LOADING FASTENERS &lt;continued&gt;

Figure 1.

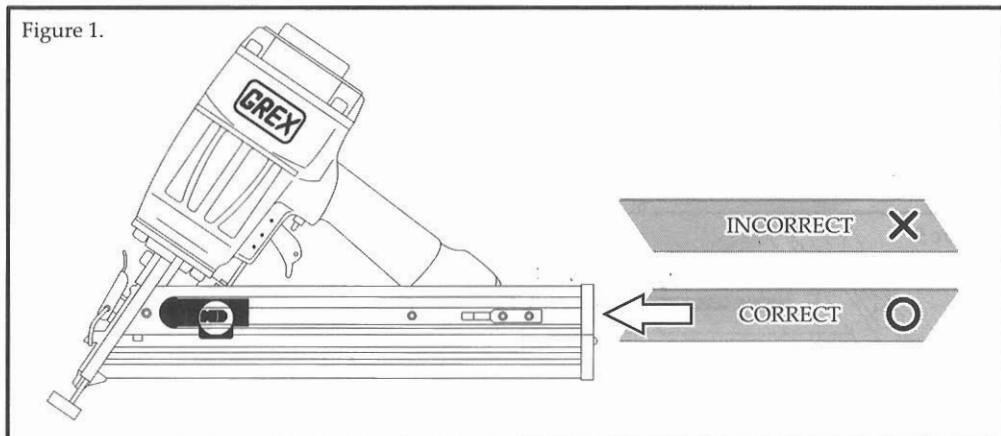

Figure 2.

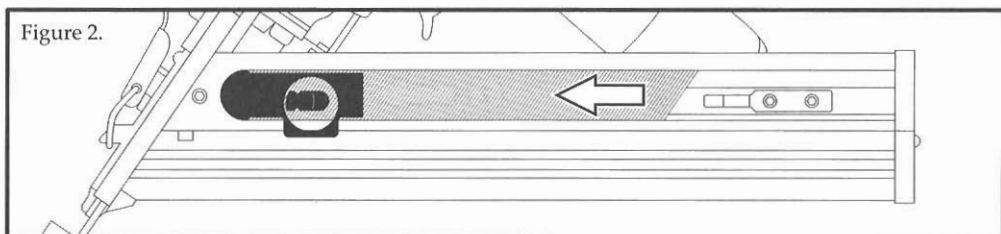

Figure 3.

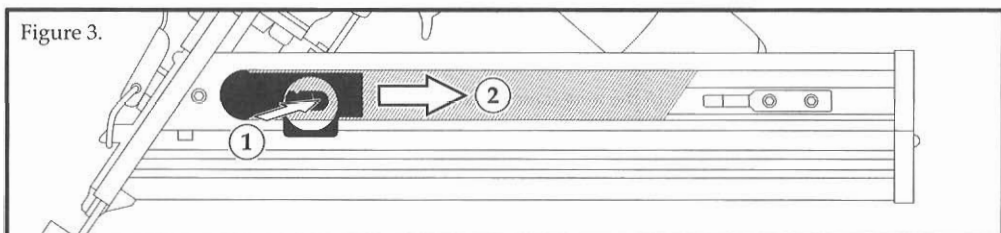
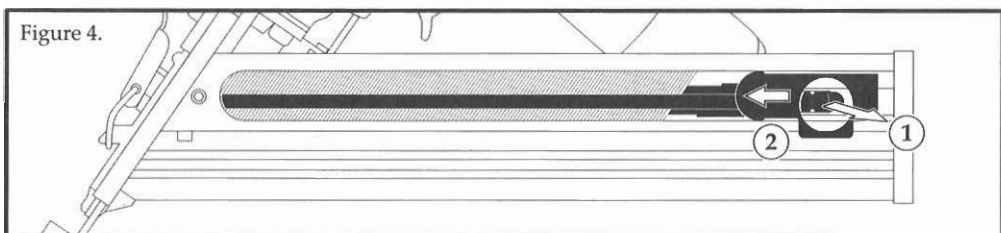

Figure 4.



**!** **CAUTION:** Read section titled "Safety Instructions" on pages 1 and 2 before operating tool.

### UN-LOADING FASTENERS

1. Disconnect tool from air supply.
2. Press down on the Pusher Lever, and then guide the Pusher to the front of the nose. Figure 5.
3. Slide the strip of fasteners toward the rear of the magazine. When the strip reaches the Nail Stop Plate, press down on the Nail Stop Plate to allow the fasteners to pass and continue to be moved out through the rear of the magazine. Figure 6.

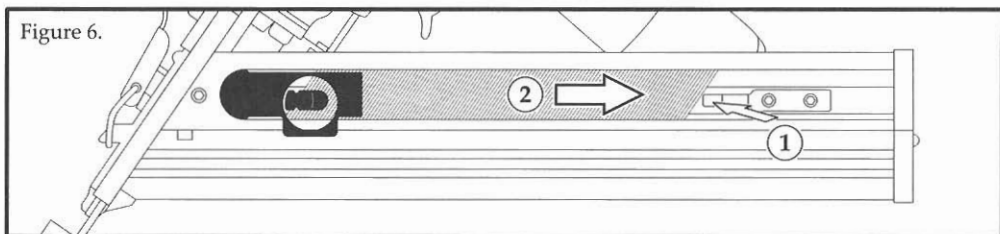
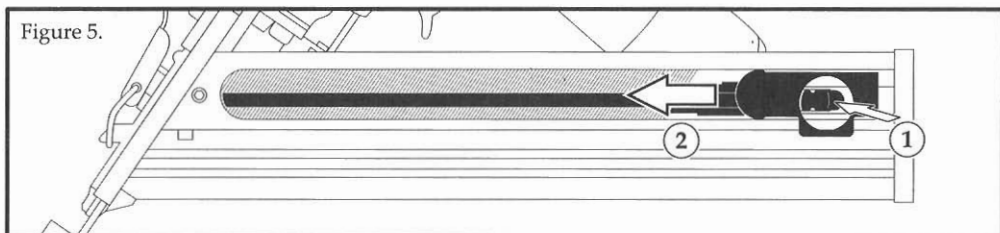

### CLEARING JAMMED FASTENERS

1. Disconnect tool from air supply.
2. Remove any remaining fasteners in the magazine. Refer to "Un-Loading Fasteners" above.
3. Open the nose cover by pulling the Quick Release Latch and then flipping the cover up. Figure 7.
4. Remove any jammed fasteners in the nose area. Use long nose pliers if necessary.
5. Close the nose cover by securing the Quick Release Latch.

### ADJUSTING THE NAILING DEPTH

1. Disconnect tool from air supply and remove finger from trigger.
2. To drive nails deeper in to the workpiece, turn Depth of Drive Dial to the LEFT. Figure 8.
3. To drive nails shallower in to the workpiece, turn the Depth of Drive Dial to the RIGHT. Figure 8. Use caution when turning dial all the way to the right. The safety may move out of alignment.
4. Before driving fasteners into the work piece, test drive fasteners on material of similar type to be used in the actual application to determine the proper dial setting.

**!** **CAUTION:** Read section titled "Safety Instructions" on pages 1 and 2 before operating tool.

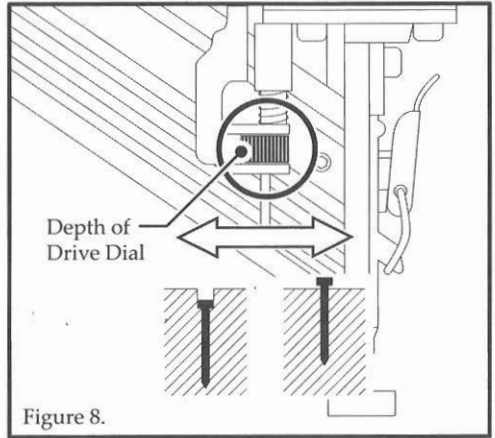
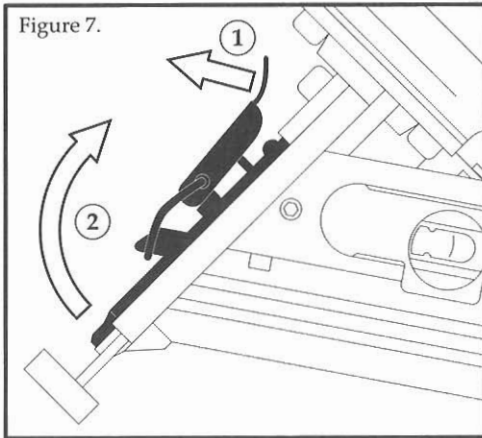

**MODES OF OPERATION**

**!** **WARNING:** NEVER point the tool towards yourself or anyone else. Keep your fingers away from the trigger when not in use. Use extreme caution when operating the tool and ALWAYS disconnect the air supply when not in use.

**SINGLE FIRING** - (1) Place contact safety of tool on desired location of work piece, press down and hold firmly (2) Pull trigger to drive fastener (3) then release trigger (4) To drive additional fasteners, move the tool to the next location and repeat Steps 1, 2 and 3. Figure 9.

**CONTACT FIRING** - (1) With tool lifted away from workpiece, pull trigger and hold (2) Depress the contact safety of the tool on the desired location of the work piece to drive fastener and then lift tool away from workpiece (3) To drive additional fasteners, move the tool to the next location and repeat Step 2 (4) As soon as desired number of nails are driven, remove finger from trigger. Figure 10.

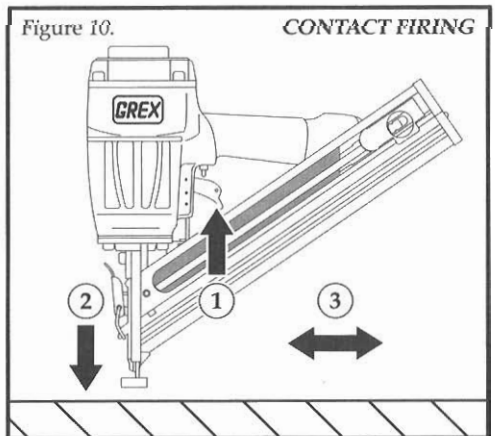
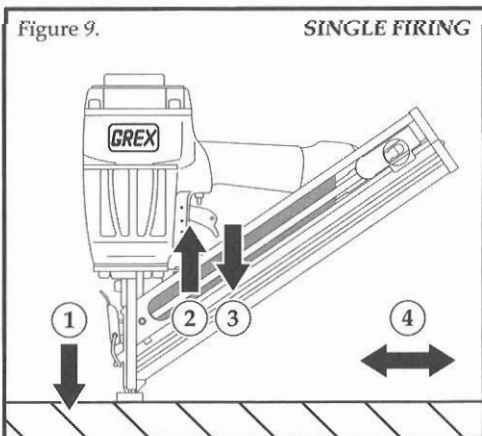



**CAUTION:** Read section titled "Safety Instructions" on pages 1 and 2 before maintaining tool.

### CLEAN AND INSPECT DAILY

**DANGER:** Never use gasoline or other flammable liquids to clean the tool. Vapors in the tool will ignite by a spark and cause the tool to explode and result in death or serious injury.

#### Wipe tool clean

Use non-flammable cleaning solutions to wipe exterior of tool only if necessary. DO NOT SOAK tool with cleaning solutions, such solutions can damage internal parts.

#### Remove tar buildup

Use kerosene # 2 fuel oil or diesel fuel. Do not allow solvent to get into the cylinder or damage may occur.

**CAUTION:** Dry off tool completely before use.

#### Clean the magazine

Remove wooden chips which may have accumulated in the magazine. Lubricate with tool lubricant.

**CAUTION:** Check that the magazine cover slides smoothly by pulling it with finger. If not smooth, fasteners can be driven at an irregular angle and hurt someone.

#### Maintain compressed air system

Drain air line filter daily to prevent accumulation of moisture and dirt by opening manual petcock. Keep lubricator filled to maintain proper lubrication to tool. Clean air filter element to prevent clogging of filter with dirt. Also drain the air compressor when not in use to keep the compressor operating properly.

### LUBRICATION

1. Tool requires lubrication before first time use and occasionally depending on frequency of tool usage.
2. First disconnect the air supply from the tool before lubricating.
3. Put in a drop of spindle oil UNOCAL RX22, or 3-in-1 oil into air inlet. Never use detergent oil or additives. Operate tool briefly after adding oil.
4. Wipe off excess oil at exhaust. Do not over lubricate, excessive oil will damage o-rings, and can mix with spent air which may stain the work surface. Blank fire the nailer (without fasteners) to purge excess oil before beginning work.

If in-line oiler is used (refer to section titled "Compressed Air System" for more information), manual lubrication through the air inlet is not required on a daily basis.

### COLD WEATHER CARE

Do not store tool in a cold weather environment. Keep tool in a warm area until the beginning of work. If tool is already cold, bring to a warm area and use the following procedures to warm up the components:

1. Reduce regulated pressure to 30 psi.
2. Remove ALL fasteners from tool.
3. Connect air hose & blank fire the tool. Slow speed operation tends to warm up moving parts.
4. Once tool is warmed up, re-adjust regulator to working pressure and reload tool.

### STORAGE

- When not in use for an extended period, apply a thin coat of lubricant to the steel parts to avoid rust.
- Do not store tool in a cold weather environment. Keep tool in a warm area.
- When not in use, the tool should be stored in a warm and dry area - out of reach of children.



**CAUTION:** Read section titled "Safety Instructions" before attempting to troubleshoot tool.  
**WARNING:** Stop using the tool immediately if any of the following problems occur. Serious personal injury could occur. Most minor problems can be resolved quickly and easily by the table below. If problems persist, contact an authorized service center only. Disconnect tool from air supply before performing any service procedures.

Symptom	Possible Cause	Remedy
Fasteners will not drive down tight.	Driver blade rounded off and slipping off staple crown or nail head.	Replace driver blade.
	Air pressure too low.	Increase to adequate air pressure.
Fasteners driven too deeply.	Worn bumper and/or piston spacer.	Replace bumper or piston spacer.
	Excessive air pressure.	Reduce to adequate air pressure.
Tool operates, but no fastener is driven.	There is a jam.	Clear jam.
	Pusher spring weakened or damaged.	Replace pusher spring.
Fastener misfire (skips).	Worn bumper.	Replace bumper.
	Dirt in nose.	Clean.
	Dirt or damage prevents fasteners from moving freely in magazine.	Clean magazine.
	Inadequate air flow to tool.	Check fitting hose of air compressor.
	Worn o-ring on piston or lack of lubrication.	Replace o-ring or lubricate.
	Damaged o-ring in trigger valve.	Replace o-rings.
	Air leaks.	Tighten screws and fittings.
	Cap seal leaking.	Replace seal.
Air leaks between housing and nose.	Loose screws in housing.	Tighten screws.
	Damaged o-rings.	Replace o-rings.
	Damaged bumper.	Replace bumper.
Sluggish operation or power loss.	Tool not lubricated sufficiently.	Lubricate tool.
	Worn out o-rings.	Replace o-rings.
	Exhaust port in cap is blocked.	Replace damaged internal parts.
Fastener jamming.	Driver guide worn or damaged.	Replace driver guide.
	Fastener size not correct.	Fasteners recommended for tool must be used.
	Fasteners are bent.	Replace with undamaged fasteners.
	Magazine or nose screws loose.	Tighten screws.
Air leaks at trigger valve area	O-rings in trigger valve are damaged.	Replace o-rings.

## TOOLS & PARTS WARRANTY

GreX Power Tools warrants its professional power tools are to be free of defects from workmanship and material for a period of one year from the date of original date of purchase (exceptions: rubber o-rings, seals, bumpers & driver blades). We will repair or replace at our option, any parts of the product and accessories covered under this warranty, which after examination, proves to be defective in workmanship or material during the warranty period. For repair or replacement, return the complete tool or accessory, transportation prepaid, to your nearest Authorized GreX Service Station. Proof of purchase may be required.

This warranty does not apply to repair or replacement required due to misuse, abuse, normal wear and tear or repairs and alterations attempted or made by other than our Service Center or Authorized Service Stations. In no event shall GreX be liable for any indirect, incidental, or consequential damage from the sale or use of this product. This disclaimer applies both during and after the term of warranty.

This is the only warranty and our company makes no warranties expressed or implied, including merchantability and fitness for a particular purpose, after the one year term of this warranty.

This limited warranty gives you specific rights, and you may also have other rights, which vary from state to state.

**For technical support and all warranty related issues, first contact GreX directly at 888-4GREXCO or [info@grexusa.com](mailto:info@grexusa.com) before returning your tool to you dealer.**

**GREX POWER TOOLS**

705 South Electric Avenue, Alhambra, CA 91803

Tel: 626-289-7618 Fax: 626-289-8121

[www.GREXUSA.com](http://www.GREXUSA.com)