

Dynamic NT Full Extension for Frameless Construction



MEPLA ALFIT

Installation Instructions

1. Determine the interior cabinet depth and choose the right slide.

Measure from outside of side panel to the cabinet back / cross stretcher. Refer to chart at right to choose correct slide. Drawer box length will correspond. (i.e. a 21" slide will use a 21" drawer box length)

2. Prepare your drawer box

A Calculate the outside drawer box width (see chart below).

Example: When using 16 mm (5/8") drawer material, the formula is: Drawer box opening minus 10 mm (3/8")

B The drawer bottom reveal is always 13 mm (1/2") deep.

C Drawer back notch = 33 mm (1 5/16")

D Drill drawer hook hole. Use Dynamic NT drill jig or drill 6 mm (1/4") diameter, 10 mm (3/8") deep, 7.5 mm (9/32") from outside edge and 11.5 mm (7/16") from bottom of notch.

Max. Drawer Material

5/8"

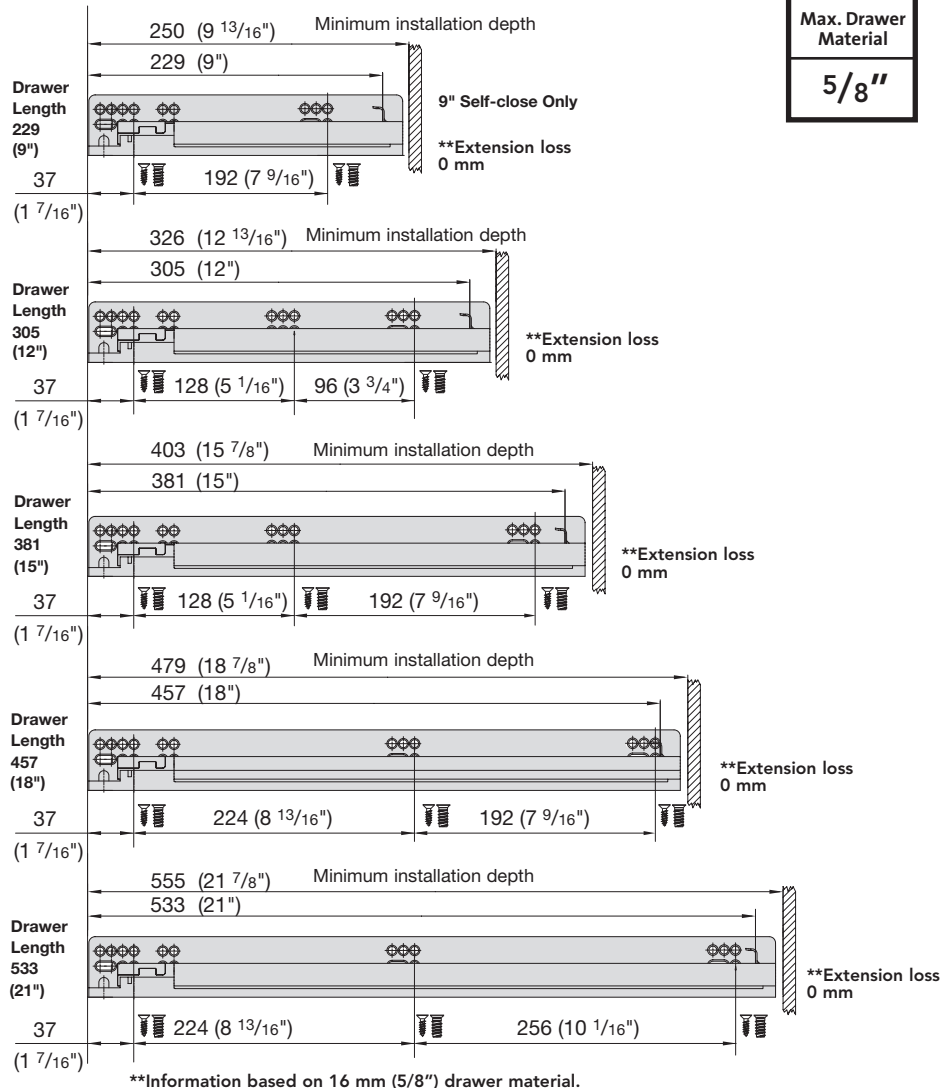

Drawer measurements

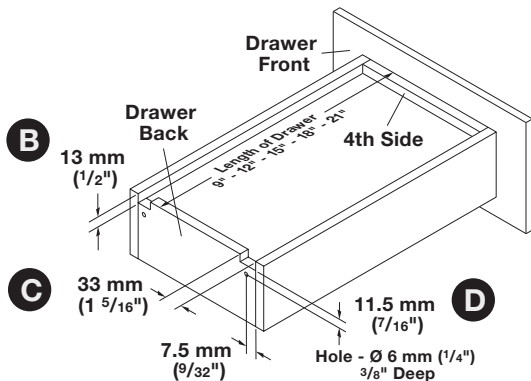

A *Calculation Outside Drawer Width

Drawer side thickness	16 (5/8")	15 (9/16")	14 (9/16")	13 (1/2")
Deduct from cabinet opening	10 (3/8")	12 (1/2")	14 (9/16")	16 (5/8")

The Dynamic NT DRILLING JIG can also locate the position of wood screws on the front fixing brackets that sometimes requires pre-drilling into hardwoods. (For example, solid maple dovetail boxes will need to pre-drill to prevent splitting. Softer 9-ply birch may not need pre-drilling.)

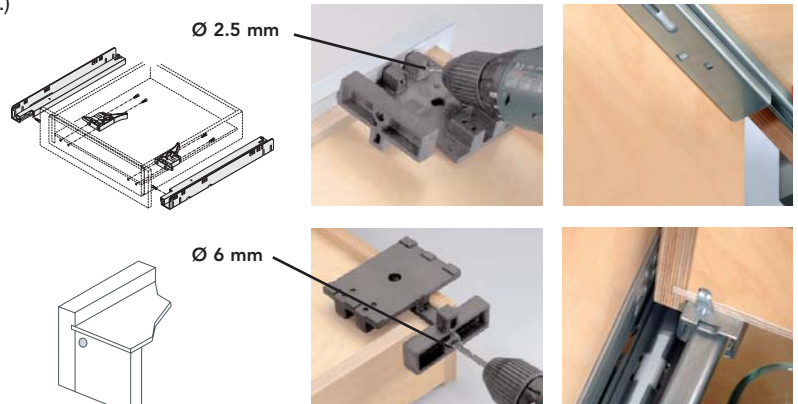

3. Layout your cabinet

- E** Calculate maximum drawer side height by measuring drawer opening minus 19 mm (3/4")

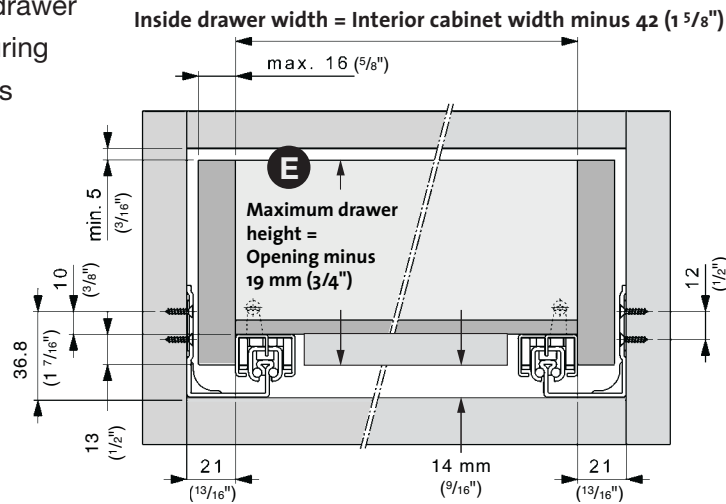

Interior and overlay application

4 sided drawer overlay application with decorative drawer front

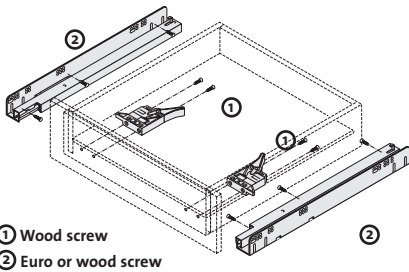

Interior drawer without decorative drawer front

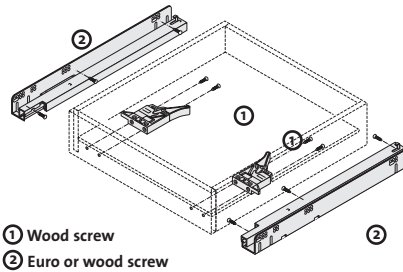

Interior drawer measurements

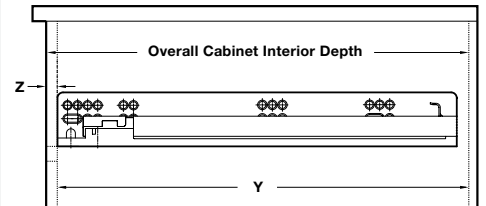

Z = Set-back. Set-back = Decorative drawer front thickness plus 5 mm (3/16")
Y = Overall cabinet depth minus set-back

General information

Height adjustment

Slide-on mounting

Integrated tool-less height adjustment up to 2.5 mm.

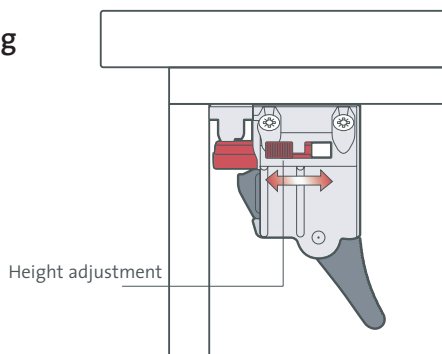

Drawer removal

Slide-on mounting

Extend drawer, press the lever of the front fixing bracket and take the drawer off from the Dynamic NT slides.

